

WEIGHTS:

CONC XX
 PUMP XX
 MOTOR XX
 METAL XX
 TOTAL XX

PUMP:

MAKE XX
 SIZE XX

MOTOR:

HP XX
 RPM XX
 FRAME XX

ISOLATION:

MODEL XX
 QUANT. XX
 DEFL. XX
 EFF. XX

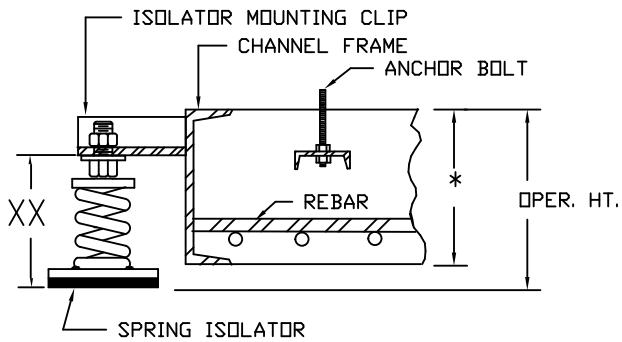

* FRAME- XX " XX # CHANNEL
 CONCRETE BY CONTRACTOR

CUSTOMER: _____

JOB NO.: _____

DATE: _____ BY: _____

CIFP BASE
 SPRING MOUNTED PUMP INERTIA BASE

DYNASONICS
INC. HOUSTON, TEXAS